



# ALMAG

## Electromagnetic Flowmeter

### Model ALMAGHP Series

## GENERAL

The **ALMAGHP** is an electromagnetic flowmeter designed to measure the flow rates of conductive liquids in applications with high operating pressures. The robust design of the ALMAGHP allows it to be used in applications with pressures in excess of 6000 psig (42 Mpa). Line sizes ranging from 1" to 8" (25 to 200 mm) can be accommodated by the ALMAGHP, with available process connections including ANSI, DIN, and JIS-type flanges. A wide selection of options is also available including integral or remote mounting, 110-220 V<sub>AC</sub> or 17-26 V<sub>DC</sub> power, and HART, RS485 & Profibus communications. The ALMAGHP's unique ability to withstand high pressures, combined with its wide array of available features, makes it an ideal choice for conductive fluids. The ALMAGHP has been successfully used in high pressure application mainly in the oil and gas industries, and a variety other of industrial high pressure applications.



## FEATURES

- ❑ Various liner/electrode material combinations can be selected in order to achieve chemical compatibility with different fluids.
- ❑ Capable of measuring fluid velocities of up to 10 m/s, with a high turndown ratio.
- ❑ A variety of flange styles including ANSI, DIN, and JIS are available.
- ❑ Suitable for high pressure operation in excess of 6000 psig.
- ❑ IP68 protection for submersible operation is available for the flow tube.
- ❑ Available FEP liner suitable for vacuum conditions.
- ❑ Excellent accuracy;  $\pm 0.5\%$  of reading standard,  $\pm 0.2\%$  optional
- ❑ Diagnostic features alert the user to empty pipe or reverse flow conditions.

## SPECIFICATIONS

- Size : 1" ~ 8" (DN25 ~ DN200)
- Measuring Range : 0.3 - 10 m/s
- Pressure : 87-6100 psig (0.6~42 Mpa)
- Process Connectio : ANSI Flange - std  
: JIS, DIN Flange - opt
- Accuracy :  $\pm 0.5\%$  of reading (fluid velocity  $\geq 0.5$  m/s)
- Materials
  - Measuring Tube : Stainless Steel #304  
Flange : Carbon Steel (standard)  
Stainless Steel #304 (Optional)  
Stainless Steel #316 (Optional)
  - Coil Housing : Carbon Steel (standard)  
Stainless Steel #304 (Optional)  
Stainless steel #316 (Optional)
  - Liners : Polyurethane, FEP, PTFE
- Enclosure : IP67 ATEX, CSA and FM
- Electrode & Grounding : Stainless Steel 316L  
Hastelloy B, Hastelloy C, Titanium,  
Tantalum  
Tungsten Carbide
- Ambient Temperature : -13 to 140 °F (-25 to 60 °C)
- Protection : IP 65 - std  
IP 68 (Submersible) - only for remote
- Conductivity : must be  $> 5 \mu\text{S/cm}$
- Grounding Resistance : Must be  $\leq 10 \Omega$
- Power requirements : 19-36 V<sub>DC</sub>, 12-15W  
85-265 V<sub>AC</sub>, 45-63 Hz,  $\leq 20\text{W}$
- Outputs : 4-20mA, Pulse,
- Communication : RS232/485/HART, Modbus
- Display : Flow rate, flow velocity, percentage,  
Total flow
- Temperature : 14 ~ 140 °F (-10 ~ 60 °C) - Polyurethane  
-40 ~ 356 °F (-40 ~ 180 °C) - FEP  
-40 ~ 356 °F (-40 ~ 180 °C) - PTFE

➤ Mounting drawing

● Standard Integral type

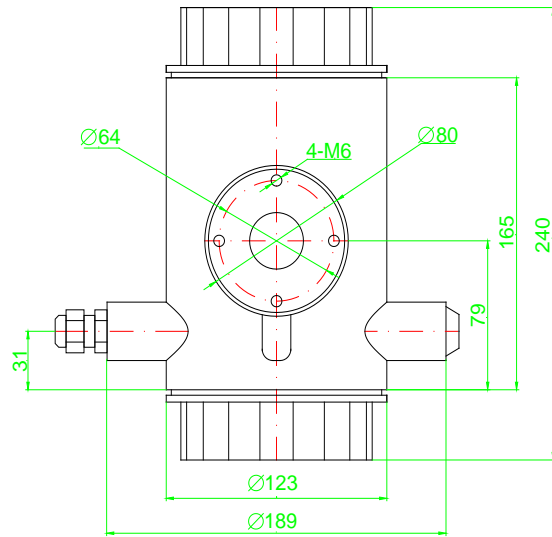
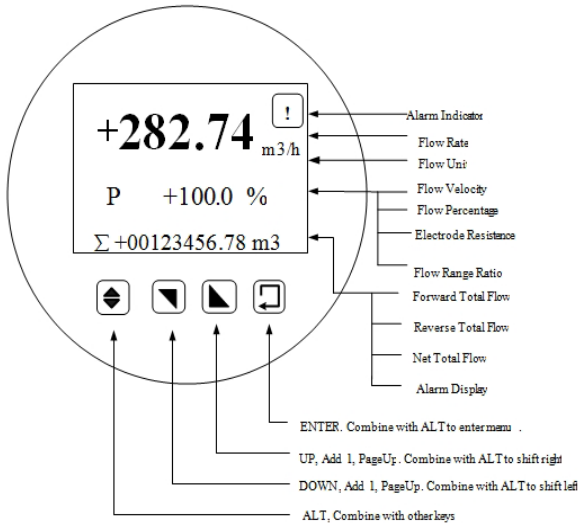

● Standard Remote type

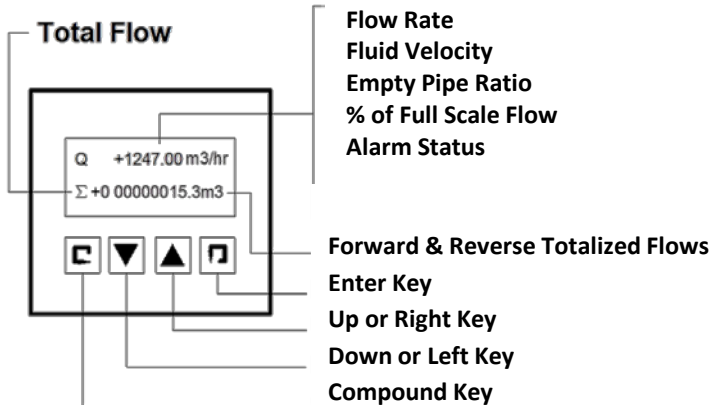
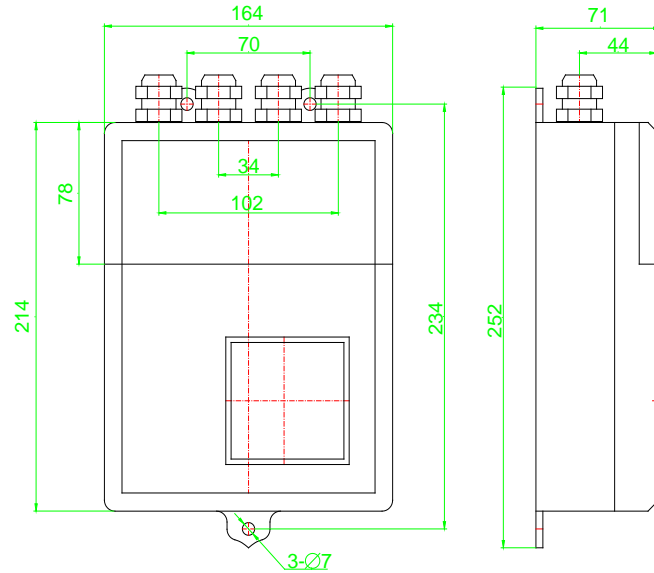

ANSI FLANGED HIGH PRESSURE DIMENSIONS

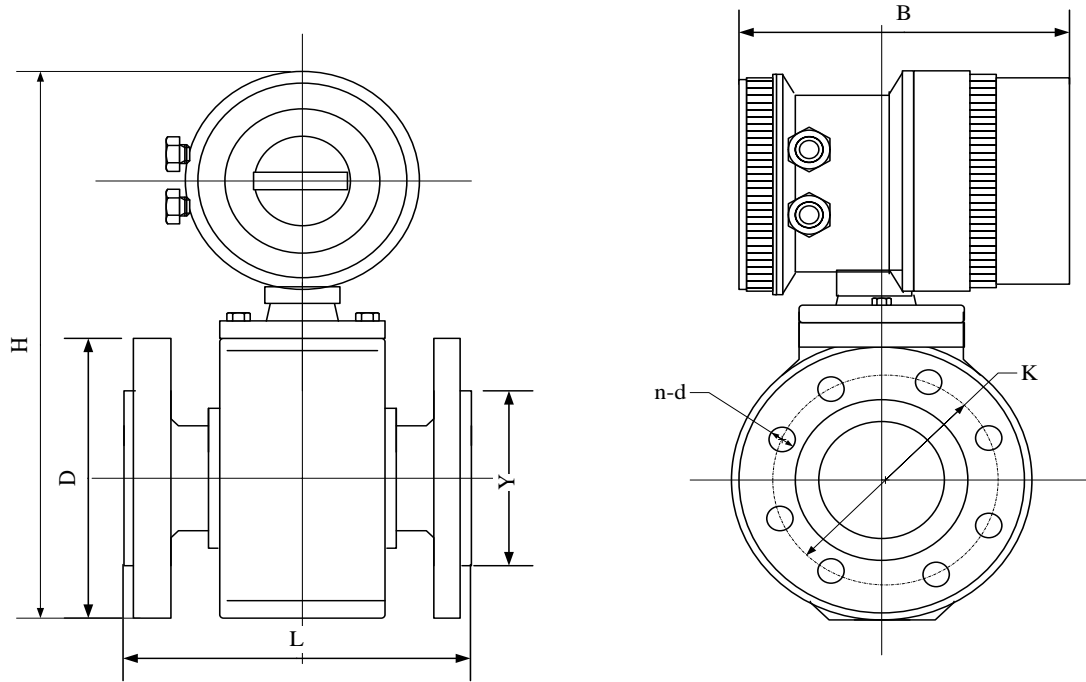

Nom. Dia.	ANSI (Class)	Dimensions (mm)						Weight - (kg)	
		L	H	B	D	K	n x dia	Integral	Remote
1" (25 mm)	600	250	350	240	110	85	4 x 3/4"	18	18
	900	250	380		140	100	4 x 1"	34	34
	1500	250	390		150	101.5	4 x 1"	39	39
	2500	300	400		160	108	4 x 1"	48	48
2" (50 mm)	600	260	425	240	185	145	8 x 3/4"	27	27
	900	260	435		195	145	8 x 1"	39	39
	1500	300	455		215	165	8 x 1"	53	53
	2500	380	475		235	171.5	8 x 1 3/16"	66	66
3" (80 mm)	600	300	460	240	220	180	8 x 7/8"	34	34
	900	300	470		230	180	8 x 1"	42	42
	1500	350	490		250	210	8 x 1 1/4"	57	57
	2500	400	490		305	228.5	8 x 1 5/8"	93	93
4" (100 mm)	600	350	525	240	275	216	8 x 1"	44	44
	900	350	530		290	235	8 x 1 1/4"	53	53
	1500	400	530		310	241.5	8 x 1 5/8"	62	62
	2500	450	595		355	273	8 x 1 5/8"	92	92
6" (150 mm)	600	350	525	240	285	240	12 x 1 3/16"	70	70
	900	350	595		355	290	12 x 1 1/4"	131	131
	1500	500	635		395	317.5	12 x 1 1/2"	177	177
	2500	/	/		/	/	8 x 2 3/16"	/	/
8" (200 mm)	600	400	660	240	420	349	12 x 1 1/4"	95	95
	900	400	725		485	393.5	12 x 1 1/2"	142	142
	1500	500	790		550	438	12 x 1 3/4"	204	204
	2500	/	/		/	/	12 x 2 3/16"	/	/

**\*\* Please contact your local Smart Measurement application engineer**

**You also need to provide the following information:**

Type of Fluid	Please provide the name of your fluid
Full Scale Flow	Maximum and minimum flow rates, units must be in GPM, LPM or m <sup>3</sup> /hr, etc..
Line Size	Please provide pipe size as well connection type (flanged, threaded, etc..)
Pressure & Temperature	We will calibrate your flowmeter as close to your operating conditions as possible

**Model Selection Guide**

ALMAGHP Series															
Example: ALMAGHP-AS-50-0-3-IN-6.4-65-0-DC-0-EXI-NN-NN															
ALMAGHP-	*_	*	*_	*	*_	*	*_	*	*_	*	*_	**_	**	Description	
ANSI Flanged	AS												Connection		
JIS Flanged	JS														
DIN Flanged	DN														
Other type flange	**														
½"-8" (DN20~DN200)	**												Size		
316 stainless steel	0												Electrode		
Nickel	1														
Hastelloy C	2														
Tan	2														
Ti	4														
PTFE	5												Liner		
PFA	6														
Integral type	IN												Transmitter		
Remote type - with 5m cable	RE														
Max Pressure up to ** Mpa	**												Pressure		
IP65	65												Protection		
IP68 flow body and IP65 transmitter, only for remote type	68														
Not Needed	0												Grounding		
Grounding electrode	1														
304SS grounding ring	2														
11-40V <sub>DC</sub>	DC												Power supply		
85~265V <sub>AC</sub> , 50/60 Hz	AC														
Non communication	0												Communication		
HART	1														
RS485 - Modbus	2														
RS485 - Profibus DP	3														
None	NX												Explosion proof		
Explosion Proof - for integral type	EXD														
Explosion Proof - for remote type	EXR														
Aluminum Enclosure, SS# 304 flow tube, carbon steel coil housing and flange	NN												Materials		
Aluminum Enclosure, SS# 304 flow tube & flanges, carbon steel coil housing	C304														
Aluminum Enclosure, SS# 304 flow tube, flanges, & coil housing	304														
None	NN												Options		
With mating carbon steel installation flange	IF														